

# STRONGWALL BARRICADES

ADA Compliant pedestrian barricades

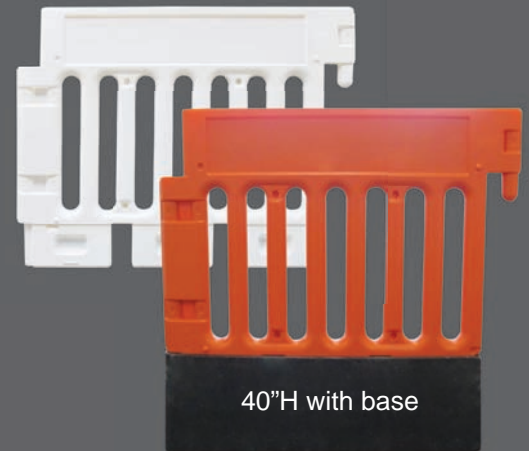

Create a temporary pedestrian walkway



40"H with base

**STRONGWALL  
ADA PEDESTRIAN BARRICADE**

## INTERCHANGEABLE BASE

Use with both Strongwall styles



**43 lb. Base  
Eliminates  
Sandbags**

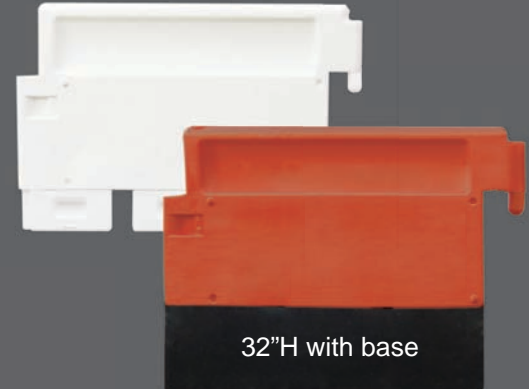

32"H with base

**STRONGWALL - LCD  
Longitudinal Channelizing Device**

- ADA Compliant, no trip hazard for pedestrians
  - meets or exceeds ADA Guidelines and MUTCD Standards
- No sandbags needed!
- Linking sections are made up of two pieces that securely fit together
  - Top Wall - rugged polyethylene
  - Bottom Base - 43 lb. self weighted black base, with carry handle
- Modular system can be shaped to any layout
- Stable in windy conditions
- Quick and easy to install
- Anti-tamper linking system
  - difficult for unauthorized personnel to dismantle when linked
- Compact stacking lowers transportation costs
- Available in orange or white, with or without retroreflective sheeting



**PLASTICADE®**

[www.plasticade.com](http://www.plasticade.com)

# STRONGWALL BARRICADES



## STRONGWALL ADA PEDESTRIAN BARRICADE

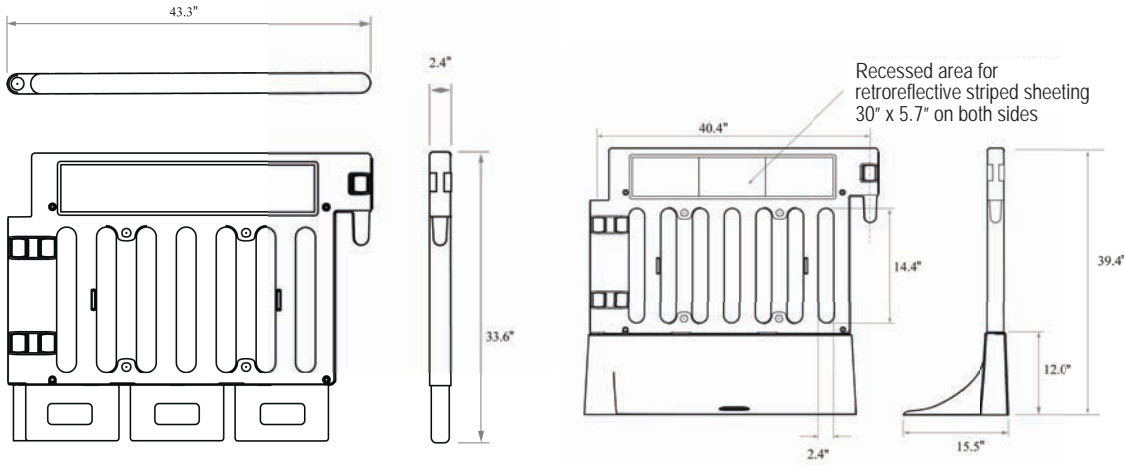

### Specs

Composition	Polyethylene
Weight	8 lbs., 51 lbs. w/base
40" H	7 lbs., 50 lbs. w/base
32" H	
Colors	Orange, White
Sheeting Area	6" x 30" on each side
Retroreflective Sheeting	Striped sheeting in engineer grade or high intensity prismatic grade
Base Dimensions	40.4" L 15.5" W 12" H
Base Weight	43 lbs.

## STRONGWALL - LCD Longitudinal Channelizing Device

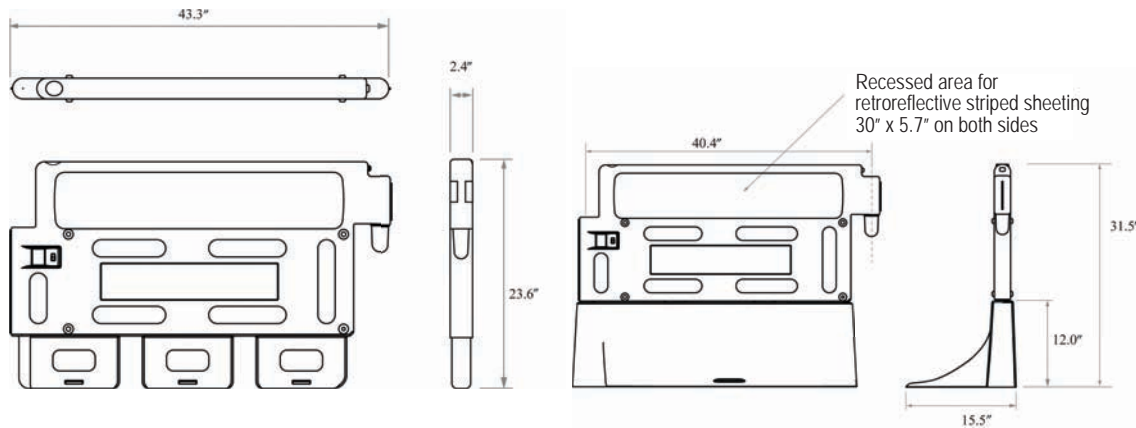

## Compact Stacking

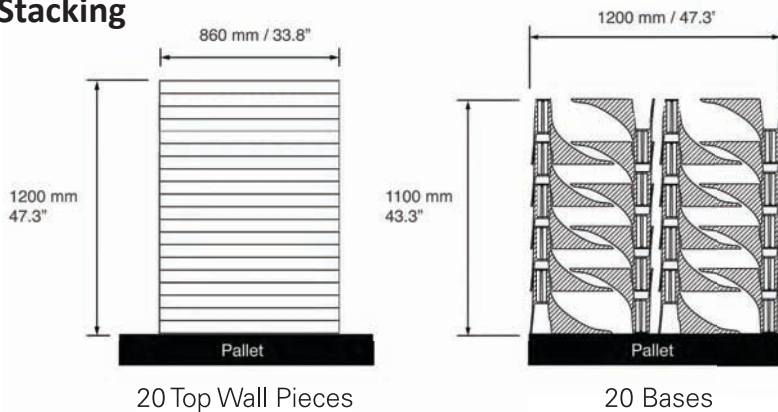

**PLASTICADE®**

7700 N. Austin Avenue

Skokie, IL 60077

phone (800) 772-0355

fax (847) 966-8074

[www.plasticade.com](http://www.plasticade.com)